

Tabla 2.A1.1. Perfiles IPN

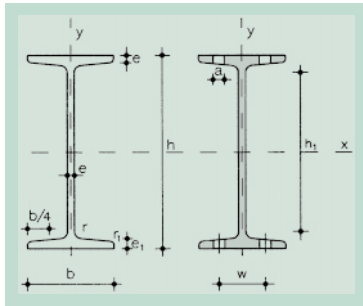

- A = Área de la sección
- S_x = Momento estático de media sección, respecto a X
- I_x = Momento de inercia de la sección, respecto a X
- $W_x = 2I_x : h$. Módulo resistente de la sección, respecto a X
- $i_x = \sqrt{I_x : A}$. Radio de giro de la sección, respecto a X
- I_y = Momento de inercia de la sección, respecto a Y
- $W_y = 2I_y : b$. Módulo resistente de la sección, respecto a Y
- $i_y = \sqrt{I_y : A}$. Radio de giro de la sección, respecto a Y
- I_t = Módulo de torsión de la sección
- I_a = Módulo de alabeo de la sección
- u = Perímetro de la sección
- a = Diámetro del agujero del roblón normal
- w = Gramil, distancia entre ejes de agujeros
- h_1 = Altura de la parte plana del alma
- e_2 = Espesor del ala en el eje del agujero
- p = Peso por m

Perfil	Dimensiones								Términos de sección							Agujeros			Peso			
	h mm	b mm	e=r mm	e_1 mm	r_1 mm	h_1 mm	u mm	A cm ²	S_x cm ³	I_x cm ⁴	W_x cm ³	i_x cm	I_y cm ⁴	W_y cm ³	i_y cm	I_t cm ⁴	I_a cm ⁶	w mm	a mm	e_2 mm	p kp/m	
IPN 80	80	42	3,9	5,9	2,3	59	304	7,58	11,4	77,8	19,5	3,20	6,29	3,00	0,91	0,93	87,5	22	—	4,43	5,95	C
IPN 100	100	50	4,5	6,8	2,7	75	370	10,60	19,9	171,0	34,2	4,01	12,20	4,88	1,07	1,72	268,0	28	—	5,05	8,32	P
IPN 120	120	58	5,1	7,7	3,1	92	439	14,20	31,8	328,0	54,7	4,81	21,50	7,41	1,23	2,92	685,0	32	—	5,67	11,20	P
IPN 140	140	66	5,7	8,6	3,4	109	502	18,30	47,7	573,0	81,9	5,61	35,20	10,70	1,40	4,66	1.540,0	34	11	6,29	14,40	P
IPN 160	160	74	6,3	9,5	3,8	125	575	22,80	68,0	935,0	117,0	6,40	54,70	14,80	1,55	7,08	3.138,0	40	11	6,91	17,90	P
IPN 180	180	82	6,9	10,4	4,1	142	640	27,90	93,4	1.450,0	161,0	7,20	81,30	19,80	1,71	10,30	5.924,0	44	13	7,53	21,90	P
IPN 200	200	90	7,5	11,3	4,5	159	709	33,50	125,0	2.140,0	214,0	8,00	117,00	26,00	1,87	14,60	10.520,0	48	13	8,15	26,30	P
IPN 220	220	98	8,1	12,2	4,9	175	775	39,60	162,0	3.060,0	278,0	8,80	162,00	33,10	2,02	20,10	17.760,0	52	13	8,77	31,10	P
IPN 240	240	106	8,7	13,1	5,2	192	844	46,10	206,0	4.250,0	354,0	9,59	221,00	41,70	2,20	27,00	28.730,0	56	17	9,39	36,20	P
IPN 260	260	113	9,4	14,1	5,6	208	906	53,40	257,0	5.740,0	442,0	10,40	288,00	51,00	2,32	36,10	44.070,0	60	17	10,15	41,90	P
IPN 280	280	119	10,1	15,2	6,1	225	966	61,10	316,0	7.590,0	542,0	11,10	364,00	61,20	2,45	47,80	64.580,0	62	17	11,04	48,00	P
IPN 300	300	125	10,8	16,2	6,5	241	1.030	69,10	381,0	9.800,0	653,0	11,90	451,00	72,20	2,56	61,20	91.850,0	64	21	11,83	54,20	P
IPN 320	320	131	11,5	17,3	6,9	257	1.090	77,80	457,0	12.510,0	782,0	12,70	555,00	84,70	2,67	78,20	128.800,0	70	21	12,72	61,10	P
IPN 340	340	137	12,2	18,3	7,3	274	1.150	86,80	540,0	15.700,0	923,0	13,50	674,00	98,40	2,80	97,50	176.300,0	74	21	13,51	68,10	P
IPN 360	360	143	13,0	19,5	7,8	290	1.210	97,10	638,0	19.610,0	1.090,0	14,20	818,00	114,00	2,90	123,00	240.100,0	76	23	14,50	76,20	P
IPN 380	380	149	13,7	20,5	8,2	306	1.270	107,00	741,0	24.010,0	1.260,0	15,00	975,00	131,00	3,02	150,00	318.700,0	82	23	15,29	84,00	P
IPN 400	400	155	14,4	21,6	8,6	323	1.330	118,00	857,0	29.210,0	1.460,0	15,70	1.160,00	149,00	3,13	183,00	419.600,0	86	23	16,18	92,60	P
IPN 450	450	170	16,2	24,3	9,7	363	1.478	147,00	1.200,0	45.850,0	2.040,0	17,70	1.730,00	203,00	3,43	288,00	791.100,0	94	25	18,35	115,00	P
IPN 500	500	185	18,0	27,0	10,8	404	1.626	180,00	1.620,0	68.740,0	2.750,0	19,60	2.480,00	268,00	3,72	449,00	1.403.000,0	100	28	20,53	141,00	P
IPN 550	550	200	19,0	30,0	11,9	445	1.787	213,00	2.120,0	99.180,0	3.610,0	21,60	3.490,00	349,00	4,02	618,00	2.389.000,0	110	28	23,00	167,00	P
IPN 600	600	215	21,6	32,4	13,0	485	1.924	254,00	2.730,0	139.000,0	4.630,0	23,40	4.670,00	434,00	4,30	875,00	3.821.000,0	120	28	24,88	199,00	P

Tabla 2.A1.2. Perfiles IPE

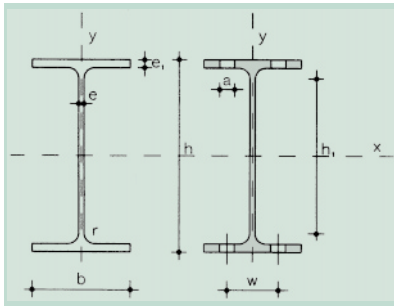

- A = Área de la sección
- S_x = Momento estático de media sección, respecto a X
- I_x = Momento de inercia de la sección, respecto a X
- $W_x = 2I_x : h$. Módulo resistente de la sección, respecto a X
- $i_x = \sqrt{I_x : A}$. Radio de giro de la sección, respecto a X
- I_y = Momento de inercia de la sección, respecto a Y
- $W_y = 2I_y : b$. Módulo resistente de la sección, respecto a Y
- $i_y = \sqrt{I_y : A}$. Radio de giro de la sección, respecto a Y
- I_t = Módulo de torsión de la sección
- I_a = Módulo de alabeo de la sección
- u = Perímetro de la sección
- a = Diámetro del agujero del roblón normal
- w = Gramil, distancia entre ejes de agujeros
- h_1 = Altura de la parte plana del alma
- p = Peso por m

Perfil	Dimensiones							Términos de sección										Agujeros			Peso	
	h mm	b mm	e mm	e ₁ mm	r ₁ mm	h ₁ mm	u mm	A cm ²	S _x cm ³	I _x cm ⁴	W _x cm ³	i _x cm	I _y cm ⁴	W _y cm ³	i _y cm	I _t cm ⁴	I _a cm ⁶	w mm	a mm	e ₂ mm	p kp/m	
IPE 80	80	46	3,8	5,2	5	60	328	7,64	11,6	80,1	20,0	3,24	8,49	3,69	1,05	0,721	118	—	—	3,8	6,00	C
IPE 100	100	55	4,1	5,7	7	75	400	10,30	19,7	171,0	34,2	4,07	15,90	5,79	1,24	1,140	351	—	—	4,1	8,10	C
IPE 120	120	64	4,4	6,3	7	93	475	13,20	30,4	318,0	53,0	4,90	27,70	8,65	1,45	1,770	890	35	—	4,4	10,40	C
IPE 140	140	73	4,7	6,9	7	112	551	16,40	44,2	541,0	77,3	5,74	44,90	12,30	1,65	2,630	1.981	40	11	4,7	12,90	C
IPE 160	160	82	5,0	7,4	9	127	623	20,10	61,9	869,0	109,0	6,58	68,30	16,70	1,84	3,640	3.959	44	13	5,0	15,80	P
IPE 180	180	91	5,3	8,0	9	146	698	23,90	83,2	1.320,0	146,0	7,42	101,00	22,20	2,05	5,060	7.431	48	13	5,3	18,80	P
IPE 200	200	100	5,6	8,5	12	159	788	28,50	110,0	1.940,0	194,0	8,26	142,00	28,50	2,24	6,670	12.990	52	13	5,6	22,40	P
IPE 220	220	110	5,9	9,2	12	178	848	33,40	143	2.770	252	9,11	205	37,3	2,48	9,15	22.670	58	17	5,9	26,20	P
IPE 240	240	120	6,2	9,8	15	190	922	39,10	183	3.890	324	9,97	284	47,3	2,69	12,00	37.390	65	17	6,2	30,70	P
IPE 270	270	135	6,6	10,2	15	220	1.040	45,90	242	5.790	429	11,20	420	62,2	3,02	15,40	70.580	72	21	6,6	36,10	P
IPE 300	300	150	7,1	10,7	15	249	1.160	53,80	314	8.360	557	12,50	604	80,5	3,35	20,10	125.900	80	23	7,1	42,20	P
IPE 330	330	160	7,5	11,5	18	271	1.250	62,60	402	11.770	713	13,70	788	98,5	3,55	26,50	199.100	85	25	7,5	49,10	P
IPE 360	360	170	8,0	12,7	18	299	1.350	72,70	510	16.270	904	15,00	1.040	123,0	3,79	37,30	313.600	90	25	8,0	57,10	P
IPE 400	400	180	8,6	13,5	21	331	1.470	84,50	654	23.130	1.160	16,50	1.320	146,0	3,95	48,30	490.000	95	28	8,6	66,30	P
IPE 450	450	190	9,4	14,6	21	379	1.610	98,80	851	33.740	1.500	18,50	1.680	176,0	4,12	65,90	791.000	100	28	9,4	77,60	P
IPE 500	500	200	10,2	16,0	21	426	1.740	116,00	1.100	48.200	1.930	20,40	2.140	214,0	4,31	91,80	1.249.000	110	28	10,2	90,70	P
IPE 550	550	210	11,1	17,2	24	468	1.880	134,00	1.390	67.120	2.440	22,30	2.670	254,0	4,45	122,00	1.884.000	115	28	11,1	106,00	C
IPE 600	600	220	12,0	19,0	24	514	2.010	155,00	1.760	92.080	3.070	24,30	3.390	308,0	4,66	172,00	2.846.000	120	28	12,0	122,0	C

Tabla 2.A1.3. Perfiles HEB, HEA y HEM

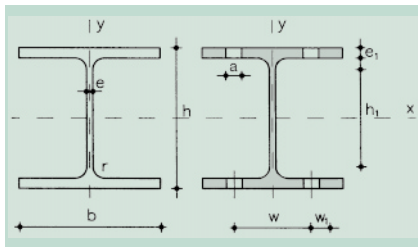

- A = Área de la sección
- S_x = Momento estático de media sección, respecto a X
- I_x = Momento de inercia de la sección, respecto a X
- $W_x = 2I_x : h$: Módulo resistente de la sección, respecto a X
- $i_x = \sqrt{I_x : A}$: Radio de giro de la sección, respecto a X
- I_y = Momento de inercia de la sección, respecto a Y
- $W_y = 2I_y : b$: Módulo resistente de la sección, respecto a Y
- $i_y = \sqrt{I_y : A}$: Radio de giro de la sección, respecto a Y
- I_t = Módulo de torsión de la sección
- I_a = Módulo de alabeo de la sección
- u = Perímetro de la sección
- a = Diámetro del agujero del roblón normal
- w = Gramil, distancia entre ejes de agujeros
- h_1 = Altura de la parte plana del alma
- p = Peso por m

Perfil	Dimensiones								Términos de sección								Agujeros			Peso		
	h mm	b mm	e mm	e_1 mm	r_1 mm	h_1 mm	u mm	A cm ²	S_x cm ³	I_x cm ⁴	W_x cm ³	i_x cm	I_y cm ⁴	W_y cm ³	i_y cm	I_t cm ⁴	I_a cm ⁶	w mm	w_1 mm		a mm	p kp/m
HEB 100	100	100	6,0	10,0	12	56	567	26,0	52,1	450	90	4,16	167	33	2,53	9,34	3.375	55	—	13	20,4	P
HEB 120	120	120	6,5	11,0	12	74	686	34,0	82,6	864	144	5,04	318	53	3,06	14,90	9.410	65	—	17	26,7	P
HEB 140	140	140	7,0	12,0	12	92	805	43,0	123,0	1.509	216	5,93	550	79	3,58	22,50	22.480	75	—	21	33,7	P
HEB 160	160	160	8,0	13,0	15	104	918	54,3	177,0	2.492	311	6,78	889	111	4,05	33,20	47.940	85	—	23	42,6	P
HEB 180	180	180	8,5	14,0	15	122	1.040	65,3	241,0	3.831	426	7,66	1.363	151	4,57	46,50	93.750	100	—	25	51,2	P
HEB 200	200	200	9,0	15,0	18	134	1.150	78,1	321,0	5.696	570	8,54	2.003	200	5,07	63,40	171.100	110	—	25	61,3	P
HEB 220	220	220	9,5	16,0	18	152	1.270	91,0	414,0	8.091	736	9,43	2.843	258	5,59	84,40	295.400	120	—	25	71,5	P
HEB 240	240	240	10,0	17,0	21	164	1.380	106,0	527,0	11.259	938	10,30	3.923	327	6,08	110,00	486.900	90	35	25	83,2	P
HEB 260	260	260	10,0	17,5	24	177	1.500	118,4	641,0	14.919	1.150	11,20	5.135	395	6,58	130,00	753.700	100	40	25	93,0	P
HEB 280	280	280	10,5	18,0	24	196	1.620	131,4	767,0	19.270	1.380	12,10	6.595	471	7,09	153,00	1.130.000	110	45	25	103,0	P
HEB 300	300	300	11,0	19,0	27	208	1.730	149,1	934,0	25.166	1.680	13,00	8.563	571	7,58	192,00	1.688.000	120	50	25	117,0	P
HEB 320	320	300	11,5	20,5	27	225	1.770	161,3	1.070,0	30.823	1.930	13,80	9.239	616	7,57	241,00	2.069.000	120	50	25	127,0	P
HEB 340	340	300	12,0	21,5	27	243	1.810	170,9	1.200,0	36.656	2.160	14,60	9.690	646	7,53	278,00	2.454.000	120	50	25	134,0	P
HEB 360	300	300	12,5	22,5	27	261	1.850	180,6	1.340,0	43.193	2.400	15,50	10.140	676	7,49	320,00	2.883.000	120	50	25	142,0	P
HEB 400	400	300	13,5	24,0	27	298	1.930	197,8	1.620,0	57.680	2.880	17,10	10.819	721	7,40	394,00	3.817.000	120	50	25	155,0	P
HEB 450	450	300	14,0	26,0	27	344	2.030	218,0	1.990,0	79.887	3.550	19,10	11.721	781	7,33	500,00	5.258.000	120	50	25	171,0	P
HEB 500	500	300	14,5	28,0	27	390	2.120	238,6	2.410,0	107.176	4.290	21,20	12.624	842	7,27	625,00	7.018.000	120	45	28	187,0	C
HEB 550	550	300	15,0	29,0	27	438	2.220	254,1	2.800,0	136.691	4.970	23,20	13.077	872	7,17	701,00	8.856.000	120	45	28	199,0	C
HEB 600	600	300	15,5	30,0	27	486	2.320	270,0	3.210,0	171.041	5.700	25,20	13.530	902	7,08	783,00	10.965.000	120	45	28	212,0	C
HEA 100	96	100	5,0	8,0	12	56	561	21,2	41,5	349	73	4,06	134	27	2,51	4,83	2.581	55	—	13	16,7	C
HEA 120	114	120	5,0	8,0	12	74	677	25,3	59,7	606	106	4,89	231	38	3,02	5,81	6.472	65	—	17	19,9	C
HEA 140	133	140	5,5	8,5	12	92	794	31,4	86,7	1.033	155	5,73	389	56	3,52	8,22	15.060	75	—	21	24,7	C
HEA 150	152	160	6,0	9,0	15	104	906	38,8	123,0	1.673	220	6,57	616	77	3,98	11,30	31.410	85	—	23	30,4	C
HEA 180	171	180	6,0	9,5	15	122	1020	45,3	162,0	2.510	294	7,45	925	103	4,52	14,70	60.210	100	—	25	35,5	C
HEA 200	190	200	6,5	10,0	18	134	1140	53,8	215,0	3.692	389	8,28	1.336	134	4,98	19,20	108.000	110	—	25	42,3	C
HEA 220	210	220	7,0	11,0	18	152	1260	64,3	284,0	5.410	515	9,17	1.955	178	5,51	28,00	193.300	120	—	25	50,5	C
HEA 240	230	240	7,5	12,0	21	164	1370	76,8	372,0	7.763	675	10,10	2.769	231	6,00	39,40	328.500	90	35	25	60,3	C
HEA 260	250	260	7,5	12,5	24	177	1480	86,8	460,0	10.455	836	11,00	3.668	282	6,50	47,80	516.400	100	40	25	68,2	C
HEA 280	270	280	8,0	13,0	24	196	1600	97,3	556,0	13.673	1.010	11,90	4.763	340	7,00	58,30	785.400	110	45	25	76,4	C
HEA 300	290	300	8,5	14,0	27	208	1720	112,5	692,0	18.263	1.260	12,70	6.310	421	7,49	77,70	1.200.000	120	50	25	88,3	C
HEA 320	310	300	9,0	15,5	27	225	1760	124,4	814,0	22.928	1.480	13,60	6.985	466	7,49	105,00	1.512.000	120	50	25	97,6	C
HEA 340	330	300	9,5	16,5	27	243	1790	133,5	925,0	27.693	1.680	14,40	7.436	496	7,46	127,00	1.824.000	120	50	25	105,0	C
HEA 360	350	300	10,0	17,5	27	261	1830	142,8	1.040,0	33.090	1.890	15,20	7.887	526	7,43	152,00	2.177.000	120	50	25	112,0	C
HEA 400	390	300	11,0	19,0	27	298	1910	159,0	1.280,0	45.069	2.310	16,80	8.564	571	7,34	197,00	2.942.000	120	50	25	125,0	C
HEA 450	440	300	11,5	21,0	27	344	2010	178,0	1.610,0	63.722	2.900	18,90	9.465	631	7,29	265,00	4.148.000	120	50	25	140,0	C
HEA 500	490	300	12,0	23,0	27	390	2110	197,5	1.970,0	86.975	3.550	21,00	10.367	691	7,24	347,00	5.643.000	120	45	28	155,0	C
HEA 550	540	300	12,5	24,0	27	438	2210	211,8	2.310,0	111.932	4.150	23,00	10.819	721	7,15	398,00	7.189.000	120	45	28	166,0	C
HEA 600	590	300	13,0	25,0	27	486	2310	226,5	2.680,0	141.208	4.790	25,00	11.271	751	7,05	454,00	8.978.000	120	45	28	178,0	C

Tabla 2.A1.3. (Continuación)

Perfil	Dimensiones							Términos de sección									Agujeros			Peso		
	h	b	e	e ₁	r ₁	h ₁	u	A	S _x	I _x	W _x	i _x	I _y	W _y	i _y	I _t	I _a	w	w ₁		a	p
	mm	mm	mm	mm	mm	mm	mm	cm ²	cm ³	cm ⁴	cm ³	cm	cm ⁴	cm ³	cm	cm ⁴	cm ⁶	mm	mm	mm	kp/m	
HEM 100	120	106	12,0	20,0	12	56	619	53,2	118,0	1.143	190	4,63	399	75	2,74	78,90	9.925	55	—	13	41,8	C
HEM 120	140	126	12,5	21,0	12	74	738	66,4	175,0	2.018	288	5,51	703	112	3,25	109,00	24.790	65	—	17	52,1	C
HEM 140	160	146	13,0	22,0	12	92	835	80,6	247,0	3.291	411	6,39	1.144	157	3,77	145,00	54.330	73	—	21	63,2	C
HEM 160	180	166	14,0	23,0	15	104	970	97,1	337,0	5.098	566	7,25	1.759	212	4,26	190,00	108.100	85	—	23	76,2	C
HEM 180	200	186	14,5	24,0	15	122	1.090	113,3	442,0	7.483	748	8,13	2.580	277	4,77	241,00	199.300	95	—	25	88,9	C
HEM 200	220	206	15,0	25,0	18	134	1.200	131,3	568,0	10.620	967	9,00	3.651	354	5,27	301,00	346.300	105	—	25	103,0	C
HEM 220	240	226	15,5	26,0	18	152	1.320	149,4	710,0	14.605	1.220	9,89	5.012	444	5,79	372,00	572.700	115	—	25	117,0	C
HEM 240	270	248	18,0	32,0	21	164	1.460	199,6	1.060,0	24.289	1.800	11,00	8.153	657	6,39	751,00	1.152.000	90	35	25	157,0	C
HEM 260	290	268	18,0	32,5	24	177	1.570	219,6	1.260,0	31.307	2.160	11,90	10.449	780	6,90	848,00	1.728.000	100	40	25	172,0	C
HEM 280	310	288	18,5	33,0	24	196	1.690	240,2	1.480,0	39.547	2.550	12,80	13.163	914	7,40	957,00	2.520.000	110	45	25	189,0	C
HEM 300	320	305	16,0	29,0	27	208	1.780	225,1	1.460,0	40.951	2.560	13,50	13.736	901	7,81	686,00	2.903.000	120	50	25	177,0	C
HEM 300	340	310	21,0	39,0	27	208	1.830	303,1	2.040,0	59.201	3.480	14,00	19.403	1.252	8,00	1.690,00	4.386.000	120	50	25	238,0	C
HEM 320	359	309	21,0	40,0	27	225	1.870	312,0	2.220,0	68.135	3.800	14,80	19.709	1.280	7,95	1.810,00	5.004.000	120	50	25	245,0	C
HEM 340	377	309	21,0	40,0	27	243	1.900	315,8	2.360,0	76.372	4.050	15,60	19.711	1.280	7,90	1.820,00	5.585.000	120	50	25	248,0	C
HEM 360	395	308	21,0	40,0	27	261	1.930	318,8	2.490,0	84.867	4.300	16,30	19.522	1.270	7,83	1.820,00	6.137.000	120	50	25	250,0	C
HEM 400	432	307	21,0	40,0	27	298	2.000	325,8	2.790,0	104.119	4.820	17,90	19.335	1.260	7,70	1.830,00	7.410.000	120	50	25	256,0	C
HEM 450	478	307	21,0	40,0	27	344	2.100	335,4	3.170,0	131.484	5.500	19,80	19.339	1.260	7,59	1.850,00	9.252.000	120	50	25	263,0	C
HEM 500	524	306	21,0	40,0	27	390	2.180	344,3	3.550,0	161.929	6.180	21,70	19.155	1.250	7,46	1.860,00	11.187.000	120	50	28	270,0	C
HEM 550	572	306	21,0	40,0	27	438	2.280	354,4	3.970,0	197.984	6.920	23,60	19.158	1.250	7,35	1.880,00	13.516.000	120	50	28	278,0	C
HEM 600	620	305	21,0	40,0	27	486	2.370	363,7	4.390,0	237.447	7.660	25,60	18.975	1.240	7,22	1.890,00	15.908.000	120	50	28	285,0	C

Tabla 2.A1.4. Perfiles UPN

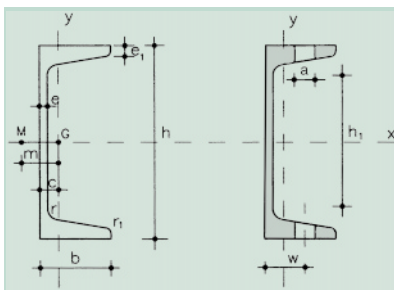

- A = Área de la sección
- S_x = Momento estático de media sección, respecto a X
- I_x = Momento de inercia de la sección, respecto a X
- W_x = 2I_x : h. Módulo resistente de la sección, respecto a X
- i_x = √(I_x/A). Radio de giro de la sección, respecto a X
- I_y = Momento de inercia de la sección, respecto a Y
- W_y = I_y : (b - c). Mínimo módulo resistente de la sección, respecto a Y
- i_y = √(I_y/A). Radio de giro de la sección, respecto a Y
- I_t = Módulo de torsión de la sección
- c = Posición del eje Y
- m = Distancia al centro de esfuerzos cortantes
- a = Diámetro del agujero del roblón normal
- w = Gramil, distancia entre ejes de agujeros
- h₁ = Altura de la parte plana del alma
- p = Peso por m
- u = Perímetro

Perfil	Dimensiones							Términos de sección									Agujeros			Peso		
	h	b	e	e ₁ =r	r ₁	h ₁	u	A	S _x	I _x	W _x	i _x	I _y	W _y	i _y	I _t	c	m	w		a	p
	mm	mm	mm	mm	mm	mm	mm	cm ²	cm ³	cm ⁴	cm ³	cm	cm ⁴	cm ³	cm	cm ⁴	cm	cm	mm	mm	kp/m	
UPN 80	80	45	6,0	8,0	4,0	46	312	11,0	15,9	106	26,5	3,10	19,4	6,36	1,33	2,24	1,45	2,67	25	13	8,64	C
UPN 100	100	50	6,0	8,5	4,5	64	372	13,5	24,5	206	41,2	3,91	29,3	8,49	1,47	2,96	1,55	2,93	30	13	10,60	P
UPN 120	120	55	7,0	9,0	4,5	82	434	17,0	36,3	364	60,7	4,62	43,2	11,10	1,59	4,30	1,60	3,03	30	17	13,40	P
UPN 140	140	60	7,0	10,0	5,0	98	489	20,4	51,4	605	86,4	5,45	62,7	14,80	1,75	6,02	1,75	3,37	35	17	16,00	P
UPN 160	160	65	7,5	10,5	5,5	115	546	24,0	68,8	925	116,0	6,21	85,3	18,30	1,89	7,81	1,84	3,56	35	21	18,80	P
UPN 180	180	70	8,0	11,0	5,5	133	611	28,0	89,6	1350	150,0	6,95	114,0	22,40	2,02	9,98	1,92	3,75	40	21	22,00	P
UPN 200	200	75	8,5	11,5	6,0	151	661	32,2	114,0	1910	191,0	7,70	148,0	27,00	2,14	12,60	2,01	3,94	40	23	25,30	P
UPN 220	220	80	9,0	12,5	6,5	167	718	37,4	146,0	2690	245,0	8,48	197,0	33,60	2,30	17,00	2,14	4,20	45	23	29,40	P
UPN 240	240	85	9,5	13,0	6,5	184	775	42,3	179,0	3600	300,0	9,22	248,0	39,60	2,42	20,80	2,23	4,39	45	25	33,20	P
UPN 260	260	90	10,0	14,0	7,0	200	834	48,3	221,0	4820	371,0	9,99	317,0	47,70	2,56	23,70	2,36	4,66	50	25	37,90	P
UPN 280	280	95	10,0	15,0	7,5	216	890	53,3	266,0	6280	448,0	10,90	399,0	57,20	2,74	33,20	2,53	5,02	50	25	41,80	P
UPN 300	300	100	10,0	16,0	8,0	232	950	58,8	316,0	8030	535,0	11,70	495,0	67,80	2,90	40,60	2,70	5,41	55	25	46,20	P

Tabla 2.A1.7. Perfiles T

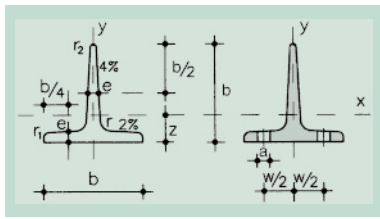

A = Área de la sección
 I_x = Momento de inercia de media sección, respecto al eje X
 $W_x = I_x : (b - z)$. Módulo resistente de la sección, respecto al eje X
 $i_x = \sqrt{I_x : A}$. Radio de giro de la sección, respecto a X
 I_y = Momento de inercia de la sección, respecto a Y

$W_y = 2I_y : b$ Módulo resistente de la sección, respecto a Y.
 $i_y = \sqrt{I_y : A}$. Radio de giro, de la secc., respecto a Y
 u = Perímetro de la sección
 p = Peso por m
 I_t = Módulo de torsión de la sección

Perfil	Dimensiones					Posición del centro	Términos de sección						Agujeros			Peso		
	b	e=r	r ₁	r ₂	u		z	A	I _x	W _x	i _x	I _y	W _y	i _y	I _t		w	a
	mm	mm	mm	mm	mm	cm	cm	cm ⁴	cm ³	cm	cm ⁴	cm ³	cm	cm ⁴	mm	mm	kp/m	
T 40 5	40	5	2,5	1,0	153	1,12	3,77	5,28	1,84	1,18	2,58	1,29	0,83	0,350	21	6,4	2,96	C
T 50 6	50	6	3,0	1,5	191	1,39	5,66	12,10	3,36	1,46	6,06	2,42	1,03	0,757	30	6,4	4,44	C
T 60 7	60	7	3,5	2,0	229	1,66	7,94	23,80	5,48	1,73	12,20	4,07	1,24	1,450	34	8,4	6,23	C
T 70 8	70	8	4,0	2,0	268	1,94	10,60	44,50	8,79	2,05	22,10	6,32	1,44	2,520	38	11,0	8,32	C
T 80 9	80	9	4,5	2,0	307	2,22	13,60	73,70	12,80	2,33	37,00	9,25	1,65	4,110	45	11,0	10,70	C
T 100 11	100	11	5,5	3,0	383	2,74	20,90	179,00	24,60	2,92	88,30	17,70	2,05	9,380	60	13,0	16,40	C

Tabla 2.A1.8. Redondos

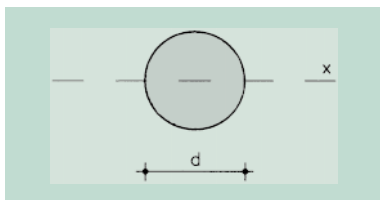

A = Área de la sección
 I_x = Momento de inercia de la sección
 $W_x = 2I_x : d$. Módulo resistente de la sección
 $i_x = \sqrt{I_x : A}$. Radio de giro de la sección
 u = Perímetro de la sección
 p = Peso por m

Producto	Dimensiones		Términos de sección				Peso	
	d	u	A	I _x	W _x	i _x		
	mm	mm	cm ²	cm ⁴	cm ³	cm	kp/m	
∅ 6	6	18,8	0,283	0,006	0,021	0,150	0,222	P
∅ 7	7	22,0	0,385	0,012	0,034	0,175	0,302	C
∅ 8	8	25,1	0,503	0,020	0,050	0,200	0,395	P
∅ 10	10	31,4	0,785	0,049	0,098	0,250	0,617	P
∅ 12	12	37,7	1,130	0,102	0,170	0,300	0,888	P
∅ 14	14	44,0	1,540	0,189	0,269	0,350	1,210	P
∅ 16	16	50,3	2,010	0,322	0,402	0,400	1,580	P
∅ 18	18	56,5	2,550	0,515	0,573	0,450	2,000	C
∅ 20	20	62,8	3,140	0,785	0,785	0,500	2,470	P
∅ 22	22	69,1	3,80	1,15	1,05	0,550	2,98	C
∅ 25	25	78,5	4,91	1,92	1,53	0,625	3,85	P
∅ 28	28	88,0	6,16	3,02	2,16	0,700	4,83	C
∅ 30	30	94,2	7,07	3,98	2,65	0,750	5,55	C
∅ 32	32	101,0	8,04	5,15	3,22	0,800	6,31	P
∅ 36	36	113,0	10,20	8,24	4,58	0,900	7,99	C
∅ 40	40	126,0	12,60	12,60	6,28	1,000	9,86	P
∅ 45	45	141,0	15,90	20,20	8,95	1,120	12,50	P
∅ 50	50	157,0	19,60	30,70	12,30	1,250	15,40	P

Tabla 2.A1.9. Cuadrados

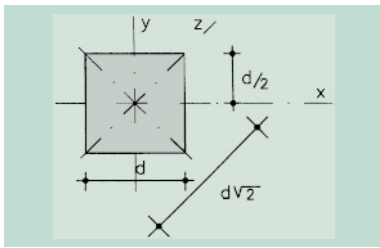

A = Área de la sección

$I_x = I_y$ Momento de inercia de la sección

$W_x = 2I_x : d$ Módulo resistente de la sección, respecto al eje X

$W_z = \sqrt{2}I_x : d$ Módulo resistente de la sección, respecto al eje Z

i_x = Radio de giro de la sección

u = Perímetro

p = Peso por m

Productol	Dimensiones		Términos de sección					Peso	
	d mm	u mm	A cm ²	$I_x = I_y$ cm ⁴	W_x cm ³	W_y cm ³	i_x cm	p kp/m	
≠ 6	6	24	0,360	0,0108	0,0360	0,0255	0,175	0,283	P
≠ 7	7	28	0,490	0,0200	0,0572	0,0404	0,202	0,385	P
≠ 8	8	32	0,640	0,0341	0,0853	0,0603	0,230	0,502	P
≠ 10	10	40	1,000	0,0833	0,1670	0,1180	0,288	0,785	P
≠ 12	12	48	1,440	0,1730	0,2880	0,2040	0,347	1,130	P
≠ 14	14	56	1,960	0,3200	0,4570	0,3230	0,404	1,540	P
≠ 16	16	64	2,560	0,5460	0,6830	0,4830	0,463	2,010	P
≠ 18	18	72	3,240	0,8750	0,9720	0,6870	0,520	2,540	P
≠ 20	20	80	4,000	1,3300	1,3300	0,9430	0,577	3,140	P
≠ 22	22	88	4,84	1,95	1,77	1,25	0,635	3,80	C
≠ 25	25	100	6,25	3,26	2,60	1,84	0,722	4,91	P
≠ 28	28	112	7,84	5,12	3,66	2,59	0,808	6,15	P
≠ 30	30	120	9,00	6,75	4,50	3,18	0,866	7,07	C
≠ 32	32	128	10,20	8,74	5,46	3,86	0,926	8,04	P
≠ 36	36	144	13,00	14,00	7,78	5,50	1,040	10,20	C
≠ 40	40	160	16,00	21,30	10,60	7,54	1,150	12,60	P
≠ 45	45	180	20,30	34,20	15,10	10,70	1,300	15,90	C
≠ 50	50	200	25,00	52,10	20,90	14,70	1,440	19,60	P

Tabla 2.A1.10. Rectangulares

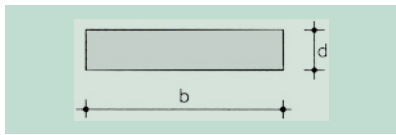

A = Área de la sección
p = Peso por m

b - d	A	p		b - d	A	p		b - d	A	p		b - d	A	p		b - d	A	p	
mm mm	cm ²	kp/m	C	mm mm	cm ²	kp/m	C	mm mm	cm ²	kp/m	C	mm mm	cm ²	kp/m	C	mm mm	cm ²	kp/m	C
20,4	0,80	0,628	C	45,12	5,40	4,24	C	70,20	14,00	11,00	P	100,30	30,00	23,60	C	160,25	40,0	31,4	C
20,5	1,00	0,785	C	45,15	6,75	5,30	C	70,25	17,50	13,70	P	100,35	35,00	27,50	C	160,30	48,0	37,7	C
20,6	1,20	0,942	C	45,20	9,00	7,07	C	70,30	21,00	16,50	C	100,40	40,00	31,40	C	160,35	56,0	44,0	C
20,8	1,60	1,260	C	45,25	11,20	8,83	C	70,35	24,50	19,20	C	110,4	4,40	3,45	C	160,40	64,0	50,2	C
20,10	2,00	1,570	C	45,30	13,50	10,60	C	70,40	28,00	22,00	C	110,5	5,50	4,32	C	180,8	14,4	11,3	C
20,12	2,40	1,880	C	45,35	15,80	12,40	C	75,4	3,00	2,36	C	110,6	6,80	5,18	C	180,10	18,0	14,1	C
20,15	3,00	2,360	C	45,40	18,00	14,10	C	75,5	3,75	2,94	C	110,8	8,80	6,91	C	180,12	21,6	17,0	C
25,4	1,00	0,785	C	50,4	2,00	1,57	P	75,6	4,50	3,53	C	110,10	11,00	8,64	C	180,15	27,0	21,2	C
25,5	1,25	0,981	C	50,5	2,50	1,96	P	75,8	6,00	4,71	C	110,12	13,20	10,40	C	180,20	36,0	28,3	C
25,6	1,50	1,180	C	50,6	3,00	2,36	P	75,10	7,50	5,89	C	110,15	16,50	13,00	C	180,25	45,0	35,3	C
25,8	2,00	1,570	C	50,8	4,00	3,14	P	75,12	9,00	7,07	C	110,20	22,00	17,30	C	180,30	54,0	42,4	C
25,10	2,50	1,960	C	50,10	5,00	3,93	P	75,15	11,20	8,83	C	110,25	27,50	21,60	C	180,35	63,0	49,5	C
25,12	3,00	2,360	C	50,12	6,00	4,71	C	75,20	15,00	11,80	C	110,30	33,00	25,90	C	180,40	72,0	56,5	C
25,15	3,75	2,940	C	50,15	7,50	5,89	C	75,25	18,80	14,70	C	110,35	38,50	30,20	C	200,8	16,0	12,6	C
25,20	5,00	3,930	C	50,20	10,00	7,85	C	75,30	22,50	17,70	C	110,40	44,00	34,50	C	200,10	20,0	15,7	C
30,4	1,20	0,942	P	50,25	12,50	9,81	C	75,35	26,20	20,60	C	120,4	4,80	3,77	C	200,12	24,0	18,8	C
30,5	1,50	1,180	P	50,30	15,00	11,80	C	75,40	30,00	23,60	C	120,5	6,00	4,71	C	200,15	30,0	23,6	C
30,6	1,80	1,410	P	50,35	17,50	13,70	C	80,4	3,20	2,51	C	120,6	7,20	5,65	C	200,20	40,0	31,4	C
30,8	2,40	1,880	C	50,40	20,00	15,70	C	80,5	4,00	3,14	C	120,8	9,60	7,54	C	200,25	50,0	39,2	C
30,10	3,00	2,360	C	55,4	2,20	1,73	C	80,6	4,80	3,77	P	120,10	12,00	9,42	P	200,30	60,0	47,1	C
30,12	3,60	2,830	C	55,5	2,75	2,16	C	80,8	6,40	5,02	P	120,12	14,40	11,30	P	200,35	70,0	55,0	C
30,15	4,50	3,530	C	55,6	3,30	2,59	C	80,10	8,00	6,28	P	120,15	18,80	14,10	P	200,40	80,0	62,8	C
30,20	6,00	4,710	C	55,8	4,40	3,45	C	80,12	9,60	7,54	P	120,20	24,00	18,80	P	250,8	20,0	15,7	C
30,25	7,50	5,890	C	55,10	5,50	4,32	C	80,15	12,00	9,42	P	120,25	30,00	23,60	P	250,10	25,0	19,6	C
35,4	1,40	1,100	C	55,12	6,60	5,18	C	80,20	16,00	12,60	P	120,30	36,00	28,50	C	250,12	30,0	23,6	C
35,5	1,75	1,370	C	55,15	8,25	6,48	C	80,25	20,00	15,70	P	120,35	42,00	33,00	C	250,15	37,5	29,4	C
35,6	2,10	1,650	C	55,20	11,00	8,64	C	80,30	24,00	18,80	C	120,40	48,00	37,70	C	250,20	50,0	39,2	C
35,8	2,80	2,200	C	55,25	13,80	10,80	C	80,35	28,00	22,00	C	140,8	11,2	8,79	C	250,25	62,5	49,1	C
35,10	3,50	2,750	C	55,30	16,50	13,00	C	80,40	32,00	25,10	C	140,10	14,0	11,00	C	250,30	75,0	58,9	C
35,12	4,20	3,300	C	55,35	19,30	15,10	C	90,4	3,60	2,85	C	140,12	16,8	13,20	P	250,35	87,5	68,7	C
35,15	5,25	4,120	C	55,40	22,00	17,30	C	90,5	4,50	3,53	C	140,15	21,0	16,50	P	250,40	100,0	78,5	C
35,20	7,00	5,500	C	60,4	2,40	1,88	C	90,6	5,40	4,24	C	140,20	28,0	22,00	P	300,8	24,0	18,8	C
35,25	8,75	6,870	C	60,5	3,00	2,36	P	90,8	7,20	5,85	C	140,25	35,0	27,50	P	300,10	30,0	23,6	C
35,30	10,50	8,240	C	60,6	3,60	2,83	P	90,10	9,00	7,07	C	140,30	42,0	33,00	C	300,12	36,0	28,3	C
40,4	1,60	1,26	P	60,8	4,80	3,77	P	90,12	10,80	8,48	C	140,35	49,0	38,50	C	300,15	45,0	35,3	C
40,5	2,00	1,57	P	60,10	6,00	4,71	P	90,15	13,50	10,60	C	140,40	56,0	44,00	C	300,20	60,0	47,1	C
40,6	2,40	1,88	P	60,12	7,20	5,65	P	90,20	18,00	12,10	C	150,8	12,0	9,42	C	300,25	75,0	58,9	C
40,8	3,20	2,51	P	60,15	9,00	7,07	P	90,25	22,50	17,70	C	150,10	15,0	11,80	C	300,30	90,0	70,6	C
40,10	4,00	3,14	C	60,20	12,00	9,42	P	90,30	27,00	21,20	C	150,12	18,0	14,10	C	300,35	105,0	82,4	C
40,12	4,80	3,77	C	60,25	15,00	11,80	P	90,35	31,50	24,70	C	150,15	22,5	17,70	C	300,40	120,0	94,2	C
40,15	6,00	4,71	C	60,30	18,00	14,10	C	90,40	36,00	28,30	C	150,20	30,0	23,60	C	400,8	32,0	25,1	C
40,20	8,00	6,28	C	60,35	21,00	16,50	C	100,4	4,00	3,14	C	150,25	37,5	29,40	C	400,10	40,0	31,4	C
40,25	10,00	7,85	C	60,40	24,00	18,80	C	100,5	5,00	3,93	C	150,30	45,0	35,30	C	400,12	48,0	37,7	C
40,30	12,00	9,42	C	70,4	2,80	2,20	C	100,6	6,00	4,71	C	150,35	52,5	41,20	C	400,15	60,0	47,1	C
40,35	14,00	11,00	C	70,5	3,50	2,75	P	100,8	8,00	6,23	P	150,40	60,0	47,10	C	400,20	80,0	62,8	C
45,4	1,80	1,41	C	70,6	4,20	3,30	P	100,10	10,00	7,85	P	160,8	12,8	10,0	C	400,25	100,0	78,5	C
45,5	2,25	1,77	C	70,8	5,60	4,40	P	100,12	12,00	9,42	P	160,10	16,0	12,6	C	400,30	120,0	94,2	C
45,6	2,70	2,12	C	70,10	7,00	5,50	P	100,15	15,00	11,80	P	160,12	19,2	15,1	C	400,35	140,0	110,0	C
45,8	3,60	2,83	C	70,12	8,40	6,59	P	100,20	20,00	15,70	P	160,15	24,0	18,8	C	400,40	160,0	126,0	C
45,10	4,50	3,53	C	70,15	10,50	8,24	P	100,25	25,00	19,60	P	160,20	32,0	25,1	C				

Tabla 2.A2.1. Perfiles huecos redondos

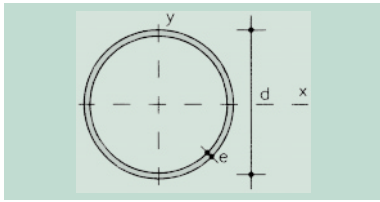

u = Perímetro

A = Área de la sección

S = Momento estático de media sección, respecto a un eje baricéntrico

I = Momento de inercia de la sección, respecto a un eje baricéntrico

$W = 2I : d$. Módulo resistente de la sección, respecto a un eje baricéntrico

$i = \sqrt{I : A}$. Radio de giro de la sección, respecto a un eje baricéntrico

I_t = Módulo de torsión de la sección

Perfil	Dimensiones			Términos de sección							Peso
	d mm	e mm	u mm	A cm ²	S cm ³	I cm ⁴	W cm ³	i cm	I _t cm ⁴	p kp/m	
Ø 40.2	40	2	126	2,39	1,44	4,33	2,16	1,35	8,66	1,88	P
Ø 40.3	40	3	126	3,49	2,05	6,01	3,00	1,31	12,00	2,74	P
Ø 40.4	40	4	126	4,52	2,60	7,42	3,71	1,28	14,80	3,55	C
Ø 45.2	45	2	141	2,70	1,85	6,26	2,78	1,52	12,50	2,12	P
Ø 45.3	45	3	141	3,96	2,65	8,77	3,90	1,49	17,50	3,11	P
Ø 45.4	45	4	141	5,15	3,37	10,90	4,84	1,45	21,80	4,04	C
Ø 50.2	50	2	157	3,02	2,30	8,70	3,48	1,69	17,40	2,37	P
Ø 50.3	50	3	157	4,43	3,31	12,20	4,91	1,66	24,50	3,47	P
Ø 50.4	50	4	157	5,78	4,23	15,40	6,16	1,63	30,80	4,53	P
Ø 55.2	55	2	173	3,33	2,81	11,70	4,25	1,87	23,40	2,61	C
Ø 55.3	55	3	173	4,90	4,06	16,60	6,04	1,84	33,20	3,85	C
Ø 55.4	55	4	173	6,41	5,21	21,00	7,64	2,01	42,00	5,03	C
Ø 60.2	60	2	188	3,64	3,36	15,30	5,11	2,05	30,60	2,86	P
Ø 60.3	60	3	188	5,37	4,87	21,80	7,29	2,01	43,70	4,21	P
Ø 60.4	60	4	188	7,04	6,27	27,70	9,24	1,98	55,40	5,52	P
Ø 65.2	65	2	204	3,96	3,97	19,70	6,06	2,23	39,40	3,11	C
Ø 65.3	65	3	204	5,84	5,78	28,10	8,65	2,19	56,20	4,58	C
Ø 65.4	65	4	204	7,67	7,46	35,80	11,60	2,16	71,60	6,02	C
Ø 70.2	70	2	220	4,27	4,62	24,70	7,05	2,41	49,40	3,35	P
Ø 70.3	70	3	220	6,31	6,73	35,50	10,10	2,37	71,00	4,95	P
Ø 70.4	70	4	220	8,29	8,72	45,30	12,90	2,34	90,60	6,51	C
Ø 75.2	75	2	236	4,58	5,33	30,50	8,15	2,58	61,10	3,60	P
Ø 75.3	75	3	236	6,78	7,78	44,00	11,70	2,54	88,00	5,32	P
Ø 75.4	75	4	236	8,92	10,10	56,30	15,00	2,51	113,00	7,00	P
Ø 80.2	80	2	251	4,90	6,09	37,30	9,33	2,76	74,60	3,85	C
Ø 80.3	80	3	251	7,26	8,90	53,90	13,50	2,72	108,00	5,70	C
Ø 80.4	80	4	251	9,55	11,60	69,10	17,30	2,69	138,00	7,50	C
Ø 90.3	90	3	283	8,19	11,40	77,60	17,30	3,07	155,00	6,43	P
Ø 90.4	90	4	283	10,80	14,80	100,00	22,30	3,04	200,00	8,48	P
Ø 90.5	90	5	283	13,40	18,10	121,00	26,90	3,01	242,00	10,50	P
Ø 100.3	100	3	314	9,14	14,10	108,00	21,50	3,43	215,00	7,17	P
Ø 100.4	100	4	314	12,10	18,40	139,00	27,80	3,39	278,00	9,47	P
Ø 100.5	100	5	314	14,90	22,60	169,00	33,80	3,36	238,00	11,70	P
Ø 100.6	100	6	314	17,70	26,50	196,00	39,30	3,33	393,00	13,90	C
Ø 125.4	125	4	393	15,20	29,30	279,00	44,60	4,28	557,00	11,90	C
Ø 125.5	125	5	393	18,80	36,00	340,00	54,40	4,24	680,00	14,80	C
Ø 125.6	125	6	393	22,40	42,50	398,00	63,70	4,21	796,00	17,60	C
Ø 155.5	155	5	487	23,60	56,20	663,00	85,50	5,30	1.330,00	18,50	C
Ø 155.6	155	6	487	28,10	66,60	781,00	101,00	5,27	1.560,00	22,10	C
Ø 155.8	155	8	487	36,90	86,50	1.000,00	129,00	5,21	2.000,00	29,00	C
Ø 175.5	175	5	550	26,70	72,30	966,00	110,00	6,01	1.330,00	21,00	C
Ø 175.6	175	6	550	31,90	85,70	1.140,00	130,00	5,98	2.280,00	25,00	C
Ø 175.8	175	8	550	42,00	112,00	1.470,00	168,00	5,92	2.940,00	33,00	C
Ø 200.5	200	5	628	30,60	95,10	1.460,00	146,00	6,91	2.920,00	24,00	C
Ø 200.6	200	6	628	36,60	113,00	1.720,00	172,00	6,86	3.440,00	28,70	C
Ø 200.8	200	8	628	48,30	148,00	2.230,00	223,00	6,79	4.460,00	37,90	C

Tabla 2.A2.2. Perfiles huecos cuadrados

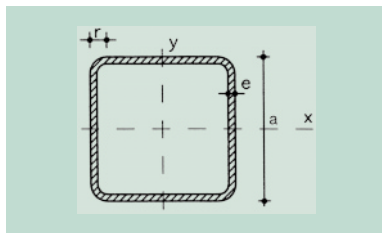

r = Radio exterior de redondeo
 u = Perímetro
 A = Área de la sección
 S = Momento estático de media sección, respecto al eje X o Y
 I = Momento de inercia de la sección, respecto al eje X o Y
 $W = 2I : d$: Módulo resistente de la sección, respecto al eje X o Y
 $i = \sqrt{I : A}$: Radio de giro de la sección, respecto al eje X o Y
 I_t = Módulo de torsión de la sección

Perfil	Dimensiones				Términos de sección						Peso	
	a mm	e mm	r mm	u mm	A cm ²	S cm ³	I cm ⁴	W cm ³	i cm	I _t cm ⁴	p kp/m	
# 40.2	40	2	5	151	2,90	2,04	6,60	3,40	1,53	11,3	2,28	P
# 40.3	40	3	8	147	4,13	2,80	9,01	4,51	1,48	15,6	3,24	P
# 40.4	40	4	10	143	5,21	3,40	10,50	5,26	1,42	18,9	4,09	P
# 45.2	45	2	5	171	3,30	2,63	9,94	4,42	1,74	16,3	2,59	C
# 45.3	45	3	8	167	4,73	3,65	13,40	5,95	1,68	22,9	3,71	C
# 45.4	45	4	10	163	6,01	4,49	15,90	7,07	1,63	28,2	4,72	C
# 50.2	50	2	5	191	3,70	3,30	13,90	5,57	1,94	22,7	2,91	P
# 50.3	50	3	8	187	5,33	4,62	19,00	7,59	1,89	32,0	4,18	P
# 50.4	50	4	10	183	5,81	5,73	22,90	9,15	1,83	39,9	5,35	P
# 55.2	55	2	5	211	4,10	4,04	18,90	6,86	2,14	30,5	3,22	C
# 55.3	55	3	8	207	5,93	5,70	25,90	9,43	2,09	43,4	4,66	C
# 55.4	55	4	10	203	7,61	7,12	31,60	11,50	2,04	54,5	5,97	C
# 60.2	60	2	5	231	4,50	4,86	24,80	8,28	2,35	39,9	3,53	P
# 60.3	60	3	8	227	6,53	6,89	34,40	11,50	2,30	57,1	5,13	P
# 60.4	60	4	10	223	8,41	8,66	42,30	14,10	2,24	72,2	6,60	P
# 60.5	60	5	13	219	10,10	10,20	48,50	16,20	2,19	85,2	7,96	C
# 70.2	70	2	5	271	5,30	6,71	40,30	11,50	2,76	64,1	4,16	P
# 70.3	70	3	8	267	7,73	9,60	56,60	16,20	2,71	92,6	6,07	P
# 70.4	70	4	10	263	10,00	12,20	70,40	20,10	2,65	118,0	7,86	P
# 70.5	70	5	13	259	12,10	14,50	82,00	23,40	2,60	141,0	9,53	P
# 80.3	80	3	8	307	8,93	12,80	86,60	21,70	3,11	140,0	7,01	P
# 80.4	80	4	10	303	11,60	16,30	108,80	27,20	3,06	180,0	9,11	P
# 80.5	80	5	13	299	14,10	19,50	128,00	32,00	3,01	217,0	11,10	P
# 80.6	80	6	15	294	16,50	22,40	144,00	36,00	2,95	250,0	13,00	C
# 90.3	90	3	8	347	10,10	16,40	126,00	37,90	3,52	202,0	7,95	P
# 90.4	90	4	10	343	13,20	21,10	159,00	35,40	3,47	281,0	10,40	P
# 90.5	90	5	13	339	16,10	25,30	189,00	41,90	3,42	316,0	12,70	P
# 90.6	90	6	15	334	18,90	29,20	214,00	47,60	3,36	366,0	14,90	P
# 100.3	100	3	8	387	11,30	20,10	175,00	35,00	3,93	279,0	8,89	P
# 100.4	100	4	10	383	14,80	26,40	223,00	44,60	3,88	363,0	11,60	P
# 100.5	100	5	13	379	18,10	31,90	266,00	53,10	3,83	440,0	14,20	P
# 100.6	100	6	15	374	21,30	37,00	304,00	60,70	3,77	513,0	16,70	P
# 120.4	120	4	10	463	18,00	38,90	397,00	66,20	4,70	638,0	14,10	P
# 120.5	120	5	13	459	22,10	47,20	478,00	79,60	4,64	780,0	17,40	P
# 120.6	120	6	15	454	26,10	55,10	551,00	91,80	4,59	913,0	20,50	C
# 140.5	140	5	13	539	26,10	65,60	780,00	111,00	5,46	260,0	20,50	P
# 140.6	140	6	15	534	30,90	76,80	905,00	129,00	5,41	480,0	24,30	P
# 140.8	140	8	20	526	40,00	97,50	1.130,00	161,00	5,30	890,0	31,40	P
# 160.5	160	5	13	619	30,10	86,90	1.190,00	149,00	6,28	1.901,0	23,70	P
# 160.6	160	6	15	614	35,70	102,00	1.390,00	173,00	6,23	2.240,0	28,00	P
# 160.8	160	8	20	609	46,40	131,00	1.740,00	218,00	6,12	2.890,0	36,50	P
# 170.5	170	5	13	659	32,10	98,70	1.440,00	169,00	6,69	2.290,0	25,20	C
# 170.6	170	6	15	654	38,10	116,00	1.680,00	198,00	6,64	2.710,0	29,90	C
# 170.8	170	8	20	646	49,60	149,00	2.120,00	249,00	6,53	3.410,0	39,00	P

Tabla 2.A2.3. Perfiles huecos rectangulares

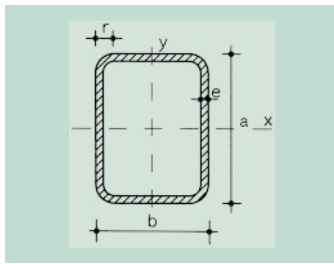

r = Radio exterior de redondeo
 u = Perímetro
 A = Área de la sección
 S_x = Momento estático de media sección, respecto al eje X
 I_x = Momento de inercia de la sección, respecto al eje X
 $W_y = 2I_x : a$. Módulo resistente de la sección, respecto al eje Y
 $i_x = \sqrt{I_x : A}$. Radio de giro de la sección, respecto al eje X
 S_y = Momento estático de media sección, respecto al eje Y
 I_y = Momento de inercia de la sección, respecto al eje Y
 $W_x = 2I_y : b$. Módulo resistente de la sección, respecto al eje X
 $i_y = \sqrt{I_y : A}$. Radio de giro de la sección, respecto al eje Y
 I_t = Módulo de torsión de la sección

Perfil	Dimensiones					Términos de sección											Peso p kp/m
	a mm	b mm	e mm	r mm	u mm	A cm ²	S _x cm ³	I _x cm ⁴	W _y cm ³	i _x cm	S _y cm ³	I _y cm ⁴	W _x cm ³	i _y cm	I _t cm ⁴		
✖ 60. 40.2	60	40	2	5	191	3,70	3,70	18,1	6,03	2,21	2,80	9,69	4,85	1,62	20,7	2,91	P
✖ 60. 40.3	60	40	3	8	187	5,33	5,18	24,7	8,23	2,15	3,91	13,10	6,56	1,57	29,2	4,18	P
✖ 60. 40.4	60	40	4	10	183	6,81	6,42	29,7	9,91	2,09	4,84	15,70	7,86	1,52	36,1	5,35	P
✖ 70. 40.2	70	40	2	5	211	4,10	4,67	26,4	7,55	2,54	3,18	11,10	5,57	1,65	25,8	3,22	C
✖ 70. 40.3	70	40	3	8	207	5,93	6,59	36,4	10,40	2,48	4,47	15,20	7,59	1,60	36,4	4,66	C
✖ 70. 40.4	70	40	4	10	203	7,61	8,23	44,3	12,60	2,41	5,56	18,30	9,16	1,55	45,3	5,97	C
✖ 70. 50.2	70	50	2	5	231	4,50	5,35	31,1	8,87	2,63	4,26	18,50	7,42	2,03	37,5	3,53	C
✖ 70. 50.3	70	50	3	8	227	6,53	7,59	43,1	12,30	2,57	6,03	25,60	10,30	1,98	53,6	5,13	C
✖ 70. 50.4	70	50	4	10	223	8,41	9,55	53,0	15,10	2,51	7,57	31,40	12,50	1,93	67,6	6,60	C
✖ 80. 40.3	80	40	3	8	227	6,53	8,15	51,0	12,80	2,79	5,02	17,20	8,62	1,62	43,8	5,13	P
✖ 80. 40.4	80	40	4	10	223	8,41	10,20	62,6	15,60	2,73	6,28	20,90	10,50	1,58	54,7	6,60	P
✖ 80. 40.5	80	40	5	13	219	10,14	12,00	71,6	17,90	2,66	7,33	23,70	11,90	1,53	63,6	7,96	C
✖ 80. 60.3	80	60	3	8	267	7,73	10,50	68,8	17,20	2,98	8,60	44,20	14,70	2,39	88,5	6,07	P
✖ 80. 60.4	80	60	4	10	263	10,00	13,30	85,7	21,40	2,93	10,90	54,90	18,30	2,34	113,0	7,86	P
✖ 80. 60.5	80	60	5	13	259	12,10	15,80	99,8	25,00	2,87	12,90	63,70	21,20	2,29	134,0	9,53	P
✖ 100. 50.3	100	50	3	8	287	8,33	13,10	105,0	20,90	3,54	8,13	35,60	14,20	2,07	88,6	6,54	P
✖ 100. 50.4	100	50	4	10	283	10,80	16,80	131,0	26,10	3,48	10,30	44,10	17,60	2,02	113,0	8,49	P
✖ 100. 50.5	100	50	5	13	279	13,10	20,00	153,0	30,60	3,41	12,20	51,10	20,40	1,97	134,0	10,31	P
✖ 100. 50.6	100	50	6	15	274	15,30	22,90	171,0	34,20	3,34	13,90	56,70	22,70	1,92	151,0	12,03	C
✖ 100. 60.4	100	60	4	10	303	11,60	18,70	149,0	29,80	3,58	13,10	67,40	22,50	2,41	156,0	9,11	P
✖ 100. 60.5	100	60	5	13	299	14,10	22,40	175,0	35,10	3,52	15,70	78,90	26,30	2,36	187,0	11,10	C
✖ 100. 60.6	100	60	6	15	294	16,50	25,70	197,0	39,50	3,46	17,90	88,40	29,50	2,31	214,0	12,97	C
✖ 100. 80.4	100	80	4	10	343	13,20	22,60	186,0	37,20	3,75	19,40	132,00	33,00	3,16	254,0	10,37	P
✖ 100. 80.5	100	80	5	13	339	16,10	27,10	221,0	44,10	3,70	23,30	156,00	39,00	3,11	307,0	12,67	P
✖ 100. 80.6	100	80	6	15	334	18,90	31,30	251,0	50,10	3,64	26,90	177,00	44,30	3,06	355,0	14,85	P
✖ 120. 60.4	120	60	4	10	343	13,20	24,90	236,0	39,30	4,22	15,40	80,00	26,70	2,46	201,0	10,37	P
✖ 120. 60.5	120	60	5	13	339	16,10	30,00	279,0	46,50	4,16	18,40	94,00	31,40	2,41	241,0	12,67	P
✖ 120. 60.6	120	60	6	15	334	18,90	34,60	317,0	52,80	4,09	21,20	106,00	35,30	2,37	277,0	14,85	P
✖ 120. 80.4	120	80	4	10	383	14,80	29,60	290,0	48,30	4,42	22,40	155,00	38,80	3,24	332,0	11,63	C
✖ 120. 80.5	120	80	5	13	379	18,10	35,70	345,0	57,60	4,36	27,00	184,00	46,10	3,19	402,0	14,24	P
✖ 120. 80.6	120	80	6	15	374	21,30	41,40	395,0	65,80	4,30	31,30	210,00	52,50	3,14	467,0	16,74	C
✖ 120. 100.4	120	100	4	10	423	16,40	34,20	343,0	57,20	4,57	30,20	260,00	57,00	3,98	479,0	12,88	P
✖ 120. 100.5	120	100	5	13	419	20,10	41,50	412,0	68,60	4,52	36,60	311,00	62,20	3,93	583,0	15,81	C
✖ 120. 100.6	120	100	6	15	414	23,70	48,30	473,0	78,80	4,46	42,60	357,00	71,40	3,88	681,0	18,62	C
✖ 140. 60.4	140	60	4	10	383	14,80	32,00	349,0	49,80	4,85	17,60	92,60	30,90	2,50	247,0	11,63	C
✖ 140. 60.5	140	60	5	13	379	18,10	38,60	415,0	59,30	4,78	21,20	109,00	36,40	2,45	297,0	14,24	C
✖ 140. 60.6	140	60	6	15	374	21,30	44,70	474,0	67,70	4,71	24,40	124,00	41,20	2,41	342,0	16,74	C
✖ 140. 80.4	140	80	4	10	423	16,40	37,40	423,0	60,40	5,08	25,40	178,00	44,60	3,30	412,0	12,88	P
✖ 140. 80.5	140	80	5	13	419	20,10	45,30	506,0	72,40	5,01	30,80	212,00	53,10	3,25	500,0	15,81	P
✖ 140. 80.6	140	80	6	15	414	23,70	52,70	582,0	83,10	4,95	35,70	243,00	60,70	3,20	582,0	18,62	P
✖ 140. 100.4	140	100	4	10	463	18,00	42,80	497,0	71,00	5,25	34,10	297,00	59,30	4,06	601,0	14,14	P
✖ 140. 100.5	140	100	5	13	459	22,10	52,10	598,0	85,40	5,20	41,40	356,00	71,20	4,01	733,0	17,38	P

Tabla 2.A2.3. (Continuación)

Perfil	Dimensiones					Términos de sección										Peso	
	a mm	b mm	e mm	r mm	u mm	A cm ²	S _x cm ³	I _x cm ⁴	W _x cm ³	i _x cm	S _y cm ³	I _y cm ⁴	W _y cm ³	i _y cm	I _t cm ⁴	p kp/m	
⌘140. 100.6	140	100	6	15	454	26,10	60,80	690,0	98,50	5,14	48,20	410,00	82,00	3,96	858,0	20,51	C
⌘160. 80.4	160	80	4	10	463	18,00	46,00	589,0	73,60	5,72	28,50	201,00	50,30	3,34	495,0	14,14	C
⌘160. 80.5	160	80	5	13	459	22,10	55,90	708,0	88,50	5,65	34,50	241,00	60,20	3,30	601,0	17,38	P
⌘160. 80.6	160	80	6	15	454	26,10	65,20	816,0	102,00	5,59	40,20	276,00	69,00	3,25	700,0	20,51	C
⌘160. 120.5	160	120	5	13	539	26,10	71,40	948,0	119,00	6,02	58,70	610,00	102,00	4,83	1.200,0	20,52	P
⌘160. 120.6	160	120	6	15	534	30,90	83,70	1.100,0	138,00	5,97	68,80	707,00	118,00	4,78	1.420,0	24,27	P
⌘160. 120.8	160	120	8	20	526	40,00	106,00	1.370,0	171,00	5,85	87,20	878,00	146,00	4,68	1.810,0	31,43	C
⌘180. 100.5	180	100	5	13	539	26,10	76,30	1.110,0	123,00	6,51	50,90	446,00	89,30	4,13	1.050,0	20,52	P
⌘180. 100.6	180	100	6	15	534	30,90	89,40	1.280,0	143,00	6,44	59,50	516,00	103,00	4,09	1.230,0	24,27	P
⌘180. 100.8	180	100	8	20	526	40,00	113,00	1.600,0	178,00	6,32	75,30	637,00	127,00	3,99	1.560,0	31,43	P
⌘180. 140.5	180	140	5	13	619	30,10	93,80	1.410,0	157,00	6,85	79,10	962,00	137,00	5,65	1.840,0	23,66	C
⌘180. 140.6	180	140	6	15	614	35,70	110,00	1.650,0	183,00	6,79	92,90	1.120,00	160,00	5,60	2.170,0	28,04	C
⌘180. 140.8	180	140	8	20	606	46,40	141,00	2.070,0	230,00	6,68	119,00	1.410,00	201,00	5,50	2.790,0	36,45	C
⌘200. 80.5	200	80	5	13	539	26,10	80,10	1.250,0	125,00	6,91	42,00	297,00	74,20	3,37	810,0	20,52	P
⌘200. 80.6	200	80	6	15	534	30,90	93,80	1.450,0	145,00	6,84	49,10	342,00	85,40	3,32	943,0	24,27	P
⌘200. 80.8	200	80	8	20	526	40,00	119,00	1.800,0	180,00	6,70	61,70	418,00	105,00	3,23	1.180,0	31,43	P
⌘200. 120.5	200	120	5	13	619	30,10	99,60	1.630,0	163,00	7,35	70,20	742,00	124,00	4,96	1.660,0	23,66	P
⌘200. 120.6	200	120	6	15	614	35,70	117,00	1.900,0	190,00	7,29	82,50	863,00	144,00	4,92	1.950,0	28,04	C
⌘200. 120.8	200	120	8	20	606	46,40	150,00	2.390,0	239,00	7,17	105,00	1.080,00	180,00	4,82	2.500,0	36,45	P
⌘200. 150.5	200	150	5	13	679	33,10	114,00	1.910,0	191,00	7,60	94,00	1.230,00	164,00	6,10	2.400,0	26,01	C
⌘200. 150.6	200	150	6	15	674	39,30	135,00	2.240,0	224,00	7,54	111,00	1.440,00	192,00	6,05	2.830,0	30,87	C
⌘200. 150.8	200	150	8	20	666	51,20	173,00	2.830,0	283,00	7,43	142,00	1.820,00	242,00	5,95	3.650,0	40,22	P

Tabla 2.A3.1. Perfiles conformados L

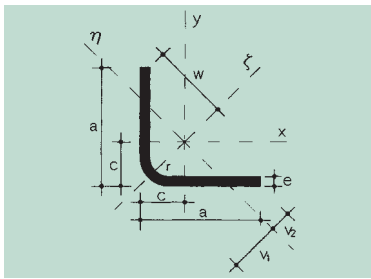

- u = Perímetro
- A = Área de la sección
- $I_x = I_y$ = Momento de inercia de la sección, respecto a x ó y
- I_{xy} = Momento centrífugo de la sección, respecto a x, y
- I_ξ = Momento de inercia de la sección, respecto a ξ
- I_η = Momento de inercia de la sección, respecto a η
- $W_x = W_y$ = Módulo resistente, respecto a x ó y
- W_ξ = Módulo resistente, respecto a ξ
- W_η = Módulo resistente, respecto a η
- $i_x = i_y$ = Radio de giro, respecto a x ó y
- i_ξ = Radio de giro, respecto a ξ
- i_η = Radio de giro, respecto a η

Perfil	Dimensiones				Posición de los ejes				Términos de sección										Peso		
	a mm	e mm	r mm	u mm	c cm	v ₁ cm	v ₂ cm	w cm	A cm ²	I _x cm ⁴	I _{xy} cm ⁴	I _ξ cm ⁴	I _η cm ⁴	W _x cm ³	W _ξ cm ³	W _η cm ³	i _x cm	i _ξ cm		i _η cm	p kp/m
LF 40.2	40	2	2,5	157	1,10	1,36	1,42	2,83	1,53	2,44	1,51	3,96	0,928	0,841	1,40	0,653	1,26	1,61	0,779	1,20	P
LF 40.3	40	3	3,0	156	1,14	1,36	1,43	2,83	2,25	3,51	2,20	5,71	1,320	1,230	2,02	0,920	1,25	1,59	0,765	1,77	C
LF 40.4	40	4	6,0	153	1,20	1,28	1,41	2,83	2,90	4,43	2,89	7,32	1,550	1,580	2,59	1,090	1,24	1,59	0,730	2,28	C
LF 50.2	50	2	3,0	197	1,35	1,70	1,77	3,54	1,93	4,85	3,00	7,85	1,850	1,330	2,22	1,050	1,59	2,02	0,980	1,51	P
LF 50.3	50	3	6,0	194	1,41	1,62	1,76	3,54	2,81	6,97	4,44	11,40	2,520	1,940	2,23	1,440	1,57	2,01	0,947	2,21	C
LF 50.4	50	4	8,0	191	1,46	1,57	1,75	3,54	3,67	8,92	5,82	14,70	3,090	2,520	4,17	1,770	1,56	2,01	0,919	2,88	C
LF 60.3	60	3	6,0	234	1,66	1,97	2,11	4,24	3,41	12,30	7,74	20,00	4,540	2,830	4,72	2,150	1,90	2,42	1,150	2,68	P
LF 60.4	60	4	8,0	231	1,71	1,92	2,10	4,24	4,47	15,80	10,20	26,00	5,660	3,690	6,13	2,690	1,88	2,41	1,130	3,51	C
LF 60.5	60	5	10,0	229	1,77	1,88	2,10	4,24	5,48	19,10	12,50	31,70	6,590	4,520	7,47	3,140	1,87	2,40	1,100	4,30	C
LF 80.4	80	4	8,0	311	2,21	2,63	2,81	5,66	6,07	38,80	24,50	63,30	14,300	6,700	11,20	5,090	2,53	3,23	1,540	4,76	P
LF 80.5	80	5	10,0	309	2,26	2,58	2,81	5,66	7,48	47,30	30,30	77,60	17,100	8,250	13,70	6,070	2,51	3,22	1,510	5,87	C
LF 80.6	80	6	12,0	307	2,32	2,53	2,80	5,66	8,85	55,40	35,90	91,30	19,400	9,750	16,10	6,940	2,50	3,21	1,480	6,95	C
LF 100.5	100	5	6,0	391	2,75	3,35	3,54	7,07	9,52	95,10	59,40	155,00	35,700	13,100	21,90	10,100	3,16	4,03	1,940	7,48	P
LF 100.6	100	6	10,0	389	2,80	3,30	3,53	7,07	11,30	112,00	70,70	183,00	41,200	15,600	25,80	11,700	3,15	4,02	1,910	8,87	C
LF 100.7	100	7	12,0	387	2,86	3,25	3,53	7,07	13,00	128,00	81,80	210,00	46,200	17,900	29,70	13,100	3,13	4,01	1,880	10,20	C
LF 120.5	120	5	8,0	471	3,25	4,05	4,25	8,49	11,50	167,00	104,00	270,00	63,400	19,100	31,90	14,900	3,61	4,84	2,350	9,05	P
LF 120.6	120	6	10,0	469	3,30	4,01	4,24	8,49	13,70	197,00	123,00	320,00	73,800	22,700	37,80	17,400	3,79	4,84	2,320	10,80	C
LF 120.7	120	7	12,0	467	3,36	3,96	4,24	8,49	15,80	226,00	143,00	369,00	83,400	26,200	43,50	19,700	3,78	4,83	2,290	12,40	C

Tabla 2.A3.2. Perfiles conformados LD

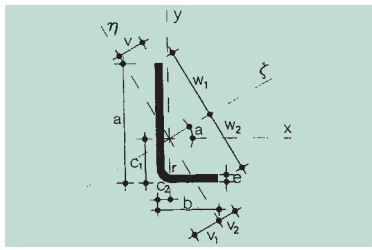

- u = Perímetro
- A = Área de la sección
- I_x = Momento de inercia de la sección, respecto a x
- I_y = Momento de inercia de la sección, respecto a y
- I_{xy} = Momento centrífugo de la sección, respecto a x, y
- I_{ξ} = Momento de inercia de la sección, respecto a ξ
- I_{η} = Momento de inercia de la sección, respecto a η
- W_x = Módulo resistente, respecto a x
- W_y = Módulo resistente, respecto a y
- W_{ξ} = Módulo resistente, respecto a ξ
- W_{η} = Módulo resistente, respecto a η
- i_x = Radio de giro, respecto a x
- i_y = Radio de giro, respecto a y
- i_{ξ} = Radio de giro, respecto a ξ
- i_{η} = Radio de giro, respecto a η

Perfil	Dimensiones			Posición de los ejes							Términos de sección										Peso								
	a	b	e	r	u	c_1	c_2	v_1	v_2	v_3	w_1	w_2	$tg \alpha$	A	I_x	I_y	I_{xy}	I_{ξ}	I_{η}	W_x		W_y	W_{ξ}	W_{η}	i_x	i_y	i_{ξ}	i_{η}	p
	mm	mm	mm	mm	mm	cm	cm	cm	cm	cm	cm	cm		cm ²	cm ⁴	cm ⁴	cm ⁴	cm ⁴	cm ⁴	cm ³	cm ³	cm ³	cm ³	cm	cm	cm	cm	kp/m	
LF 40.20.2	40	20	2	2,5	117	1,45	0,421	0,697	1,18	0,491	2,57	1,83	0,287	1,13	1,90	0,344	0,487	2,05	0,204	0,746	0,218	0,796	0,174	1,30	0,552	1,35	0,425	0,887	P
LF 40.20.3	40	20	3	3,0	116	1,50	0,462	0,714	1,15	0,531	2,53	1,86	0,288	1,65	2,71	0,480	0,693	2,91	0,282	1,080	0,312	1,150	0,246	1,28	0,539	1,33	0,413	1,300	C
LF 50.25.2	50	25	2	2,5	147	1,78	0,504	0,867	1,49	0,592	3,23	2,26	0,286	1,43	3,81	0,692	0,969	4,09	0,415	1,180	0,347	1,260	0,279	1,63	0,696	1,69	0,559	1,120	P
LF 50.25.3	50	25	3	3,0	146	1,83	0,545	0,884	1,45	0,632	3,20	2,30	0,285	2,10	5,48	0,980	1,390	5,88	0,583	1,730	0,501	1,840	0,399	1,61	0,683	1,67	0,527	1,650	C
LF 60.30.3	60	30	3	3,0	176	2,16	0,629	1,050	1,77	0,733	3,86	2,73	0,284	2,55	9,69	1,740	2,460	10,40	1,050	2,530	0,735	2,690	0,590	1,35	0,827	2,02	0,640	2,000	P
LF 60.30.4	60	30	4	6,0	173	2,24	0,679	1,040	1,71	0,786	3,80	2,80	0,292	3,30	12,30	2,200	3,220	13,20	1,260	3,260	0,948	3,480	0,736	1,93	0,816	2,00	0,617	2,590	C
LF 80.40.4	80	40	4	6,0	233	2,91	0,845	1,380	2,34	0,988	5,13	3,67	0,289	4,50	30,30	5,490	7,840	32,60	3,220	5,950	1,740	6,360	1,380	2,60	1,100	2,69	0,848	3,530	P
LF 80.40.5	80	40	5	8,0	231	2,97	0,893	1,380	2,20	1,040	5,07	3,73	0,293	5,52	36,60	6,590	9,620	39,40	3,770	7,290	2,120	7,770	1,650	2,57	1,090	2,67	0,828	4,340	C
LF 100.50.5	100	50	5	8,0	291	3,64	1,060	1,720	2,91	1,240	6,40	4,59	0,290	7,02	73,90	13,400	19,200	79,50	7,810	11,600	3,390	12,400	2,680	3,24	1,380	3,36	1,060	5,510	P
LF 100.50.6	100	50	6	10,0	289	3,71	1,110	1,720	2,86	1,290	6,35	4,65	0,293	8,30	86,20	15,600	22,700	92,90	8,900	13,700	3,990	14,600	3,110	3,22	1,370	3,35	1,040	6,520	C
LF 120.60.5	120	60	5	8,0	351	4,30	1,220	2,060	3,53	1,440	7,73	5,46	0,299	8,52	130,00	23,700	33,600	140,00	14,000	16,900	4,970	18,100	3,970	3,91	1,670	4,05	1,280	6,690	P
LF 120.60.6	120	60	6	10,0	349	4,37	1,270	2,060	3,49	1,490	7,68	5,52	0,291	10,10	153,00	27,700	39,800	165,00	16,100	20,000	5,860	21,400	4,630	3,89	1,660	4,04	1,260	7,930	C

Tabla 2.A3.3. Perfiles conformados U

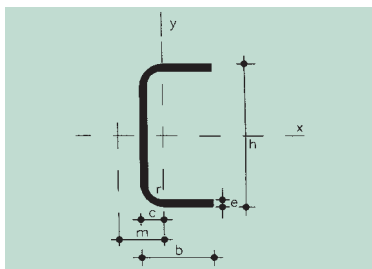

- u = Perímetro
- c = Posición del eje Y
- m = Distancia al centro de esfuerzos cortantes
- A = Área de la sección
- I_x = Momento de inercia de la sección, respecto a x
- I_y = Momento de inercia de la sección, respecto a y
- I_t = Momento de torsión de la sección
- I_s = Módulo de alabeo de la sección
- W_x = Módulo resistente, respecto a x
- W_y = Módulo resistente, respecto a y
- i_x = Radio de giro, respecto a x
- i_y = Radio de giro, respecto a y

Perfil	Dimensiones					Términos de sección										Peso		
	h	b	e	r	u	c	m	A	I_x	I_y	I_t	I_s	W_x	W_y	i_x		i_y	p
	mm	mm	mm	mm	mm	cm	cm	cm ²	cm ⁴	cm ⁴	cm ⁴	cm ⁶	cm ³	cm ³	cm	cm	kp/m	
UF 60.3	60	30	3	3	226	0,890	1,85	3,30	17,5	2,85	0,0991	14,8	5,85	1,35	2,31	0,93	2,59	C
UF 60.4	60	30	4	6	218	0,954	1,85	4,20	21,1	3,51	0,2240	15,8	7,03	1,72	2,24	0,91	3,30	C
UF 80.3	80	40	3	3	306	1,140	2,48	4,50	43,9	7,03	0,1350	69,0	11,00	2,46	3,12	1,25	3,53	P
UF 80.4	80	40	4	6	298	1,200	2,49	5,80	54,3	8,88	0,3100	79,3	13,60	3,17	3,06	1,24	4,55	C
UF 80.5	80	40	5	8	292	1,260	2,48	7,04	63,4	10,50	0,5870	85,7	15,90	3,84	3,00	1,22	5,52	C
UF 100.3	100	50	3	3	386	1,390	3,10	5,70	88,4	14,10	0,1710	223,0	17,70	3,90	3,94	1,57	4,48	P
UF 100.4	100	50	4	6	378	1,450	3,12	7,40	111,0	18,00	0,3950	226,0	22,20	5,07	3,88	1,56	5,81	C
UF 100.5	100	50	5	8	372	1,510	3,12	9,04	132,0	21,60	0,7540	299,0	26,40	6,19	3,82	1,55	7,09	C
UF 120.4	120	60	4	6	458	1,700	3,75	9,00	198,0	31,90	0,4800	702,0	33,10	7,42	4,70	1,88	7,06	P
UF 120.5	120	60	5	8	452	1,750	3,75	11,00	238,0	38,60	0,9210	808,0	39,60	9,08	4,64	1,87	8,66	C
UF 120.6	120	60	6	10	446	1,810	3,75	13,00	273,0	44,80	1,5600	886,0	45,50	10,70	4,58	1,86	10,20	C
UF 140.4	140	70	4	6	538	1,950	4,38	10,60	322,0	51,60	0,5660	1.580,0	46,00	10,20	5,51	2,21	8,32	P
UF 140.5	140	70	5	8	532	2,000	4,38	13,00	388,0	62,70	1,0900	1.850,0	55,50	12,50	5,46	2,19	10,20	C
UF 140.6	140	70	6	10	526	2,060	4,38	15,40	449,0	73,10	1,8500	2.060,0	64,20	14,80	5,40	2,18	12,10	C

Tabla 2.A3.4. Perfiles conformados C

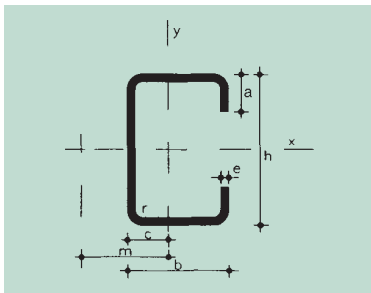

- u = Perímetro
- c = Posición del eje Y
- m = Distancia al centro de esfuerzos cortantes
- A = Área de la sección
- I_x = Momento de inercia de la sección, respecto a x
- I_y = Momento de inercia de la sección, respecto a y
- I_t = Momento de torsión de la sección
- I_a = Módulo de alabeo de la sección
- W_x = Módulo resistente, respecto a x
- W_y = Módulo resistente, respecto a y
- i_x = Radio de giro, respecto a x
- i_y = Radio de giro, respecto a y

Perfil	Dimensiones								Términos de sección										Peso
	h mm	b mm	a mm	e mm	r mm	u mm	c cm	m cm	A cm ²	I_x cm ⁴	I_y cm ⁴	I_t cm ⁴	I_a cm ⁶	W_x cm ³	W_y cm ³	i_x cm	i_y cm	p kp/m	
CF 60,2,0	60	40	15	2,0	2,5	316	1,63	3,72	3,12	17,8	7,16	0,0416	74,9	5,93	3,03	2,39	1,52	2,45	P
CF 60,2,5	60	40	15	2,5	2,5	312	1,63	3,62	3,84	21,5	8,56	0,0800	90,4	7,16	3,62	2,37	1,49	3,01	C
CF 60,3,0	60	40	15	3,0	3,0	307	1,63	3,45	4,50	24,6	9,71	0,1350	109,0	8,22	4,10	2,34	1,47	3,53	C
CF 80,2,0	80	40	15	2,0	2,5	356	1,46	3,40	3,52	34,9	8,00	0,0469	122,0	8,74	3,15	3,15	1,51	2,76	P
CF 80,2,5	80	40	15	2,5	2,5	352	1,46	3,31	4,34	42,4	9,57	0,0904	148,0	10,60	3,77	3,13	1,49	3,40	C
CF 80,3,0	80	40	15	3,0	3,0	347	1,46	3,17	5,10	49,0	10,90	0,1530	179,0	12,30	4,28	3,10	1,46	4,00	C
CF 100,2,0	100	40	15	2,0	2,5	396	1,32	3,14	3,92	59,2	8,67	0,0523	189,0	11,80	3,24	3,89	1,49	3,08	P
CF 100,2,5	100	40	15	2,5	2,5	392	1,32	3,06	4,84	72,1	10,40	0,1010	228,0	14,40	3,87	3,86	1,46	3,80	C
CF 100,3,0	100	40	15	3,0	3,0	387	1,32	2,94	5,70	83,6	11,80	0,1710	275,0	16,70	4,40	3,83	1,44	4,48	C
CF 120,2,0	120	50	20	2,0	2,5	496	1,72	4,22	4,92	109,0	17,90	0,0656	547,0	18,10	6,47	4,70	1,91	3,86	P
CF 120,2,5	120	50	20	2,5	2,5	492	1,72	4,14	6,09	133,0	21,70	0,1270	668,0	22,20	6,61	4,68	1,89	4,78	C
CF 120,3,0	120	50	20	3,0	3,0	487	1,72	4,02	7,20	156,0	25,00	0,2160	808,0	25,90	7,61	4,65	1,86	5,65	C
CF 140,2,0	140	50	20	2,0	2,5	536	1,60	3,97	5,32	156,0	18,90	0,0709	751,0	22,30	5,56	5,42	1,89	4,17	P
CF 140,2,5	140	50	20	2,5	2,5	532	1,60	3,89	6,59	192,0	22,90	0,1370	917,0	27,40	6,72	5,40	1,86	5,17	C
CF 140,3,0	140	50	20	3,0	3,0	527	1,60	3,78	7,80	225,0	26,30	0,2340	1.105,0	32,10	7,74	5,37	1,84	6,13	C
CF 160,2,0	160	60	20	2,0	2,5	616	1,86	4,62	6,12	240,0	30,50	0,0816	1.493,0	30,00	7,37	6,26	2,23	4,80	P
CF 160,2,5	160	60	20	2,5	2,5	612	1,86	4,54	7,59	295,0	37,00	0,1580	1.627,0	36,80	8,95	6,23	2,21	5,95	C
CF 160,3,0	160	60	20	3,0	3,0	607	1,86	4,43	9,00	346,0	42,90	0,2700	2.192,0	43,30	10,40	6,20	2,18	7,07	C
CF 180,2,0	180	60	20	2,0	2,5	656	1,75	4,40	6,52	316,0	31,7	0,0869	1.930,0	35,1	7,46	6,97	2,20	5,12	P
CF 180,2,5	180	60	20	2,5	2,5	652	1,75	4,35	8,09	389,0	38,5	0,1690	2.360,0	43,2	9,06	6,94	2,18	6,35	C
CF 180,3,0	180	60	20	3,0	3,0	647	1,75	4,22	9,60	458,0	44,50	0,2880	2.825,0	50,90	10,50	6,91	2,15	7,54	C
CF 200,2,0	200	60	20	2,0	2,5	696	1,66	4,20	6,92	406,0	32,70	0,0923	2.438,0	40,60	7,53	7,66	2,17	5,43	P
CF 200,2,5	200	60	20	2,5	2,5	692	1,66	4,13	8,59	500,0	39,70	0,1790	2.981,0	50,00	9,15	7,63	2,15	6,74	C
CF 200,3,0	200	60	20	3,0	3,0	687	1,66	4,04	10,20	588,0	46,00	0,3060	3.561,0	58,80	10,60	7,60	2,12	8,01	C
CF 225,2,5	225	80	25	2,5	2,5	842	2,38	5,96	10,50	806,0	90,80	0,2180	8.320,0	71,70	16,20	8,78	2,95	8,21	P
CF 225,3,0	225	80	25	3,0	3,0	837	2,38	5,86	12,50	953,0	106,00	0,3740	9.970,0	84,70	18,90	8,75	2,92	9,78	C
CF 225,4,0	225	80	25	4,0	6,0	819	2,36	5,53	16,20	1.213,0	131,00	0,8650	14.057,0	108,00	23,30	8,66	2,85	12,70	C
CF 250,2,5	250	80	25	2,5	2,5	892	2,25	5,70	11,10	1.083,0	93,80	0,2310	15.028,0	82,60	16,30	9,65	2,91	8,70	P
CF 250,3,0	250	80	25	3,0	3,0	887	2,25	5,60	13,20	1.222,0	110,00	0,3960	12.601,0	97,70	19,10	9,62	2,88	10,40	C
CF 250,4,0	250	80	25	4,0	6,0	869	2,23	5,30	17,20	1.559,0	136,00	0,9180	17.607,0	125,00	23,50	9,52	2,81	13,50	C
CF 275,2,5	275	80	25	2,5	2,5	942	2,14	6,47	11,70	1.259,0	96,50	0,2440	13.061,0	94,10	16,50	10,50	2,87	9,19	P
CF 275,3,0	275	80	25	3,0	3,0	937	2,14	6,37	14,00	1.532,0	113,00	0,4290	15.611,0	111,00	19,20	10,50	2,84	11,00	C
CF 275,4,0	275	80	25	4,0	6,0	912	2,12	6,09	18,20	1.959,0	140,00	0,9710	21.655,0	142,00	23,80	10,40	2,77	14,30	C
CF 300,2,5	300	80	25	2,5	2,5	992	2,04	5,25	12,30	1.592,0	98,90	0,2571	15.931,0	106,00	16,60	11,40	2,83	9,68	P
CF 300,3,0	300	80	25	3,0	3,0	987	2,04	5,16	14,70	1.885,0	116,00	0,4410	19.017,0	126,00	19,40	11,30	2,80	11,50	C
CF 300,4,0	300	80	25	4,0	6,0	969	2,02	4,89	19,20	2.415,0	143,00	1,0200	26.216,0	161,00	24,00	11,20	2,73	15,10	C

Tabla 2.A3.5. Perfiles conformados Ω (omega)

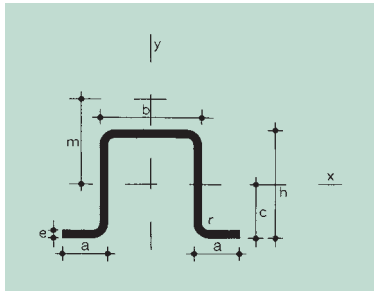

- u = Perímetro
- c = Posición del eje Y
- m = Distancia al centro de esfuerzos cortantes
- A = Área de la sección
- I_x = Momento de inercia de la sección, respecto a x
- I_y = Momento de inercia de la sección, respecto a y
- I_t = Momento de torsión de la sección
- I_a = Módulo de alabeo de la sección
- W_x = Módulo resistente, respecto a x
- W_y = Módulo resistente, respecto a y
- i_x = Radio de giro, respecto a x
- i_y = Radio de giro, respecto a y

Perfil	Dimensiones						Términos de sección											Peso	
	h mm	b mm	a mm	e mm	r mm	u mm	c cm	m cm	A cm ²	I_x cm ⁴	I_y cm ⁴	I_t cm ⁴	I_a cm ⁶	W_x cm ³	W_y cm ³	i_x cm	i_y cm	p kp/m	
OF 40.2.0	40	40	15	2,0	2,5	272	2,14	3,46	2,72	6,08	9,84	0,0363	10,5	2,84	2,98	1,50	1,90	2,13	P
OF 40.2.5	40	40	15	2,5	2,5	267	2,14	3,42	3,34	7,24	11,70	0,0696	12,0	3,38	3,61	1,47	1,88	2,62	C
OF 40.3.0	40	40	15	3,0	3,0	261	2,14	3,39	3,91	8,17	13,30	0,1170	12,9	3,81	4,17	1,45	1,85	3,07	C
OF 50.2.0	50	50	17	2,0	2,5	340	2,73	4,38	3,40	12,00	18,90	0,0453	33,2	4,40	4,72	1,88	2,36	2,67	P
OF 50.2.5	50	50	17	2,5	2,5	335	2,73	4,34	4,19	14,40	22,80	0,0873	38,8	5,29	5,76	1,86	2,33	3,29	C
OF 50.3.0	50	50	17	3,0	3,0	329	2,73	4,31	4,93	16,50	26,10	0,1480	42,7	6,04	6,70	1,83	2,30	3,87	C
OF 60.2.0	60	40	20	2,0	2,5	372	3,00	5,19	3,72	18,20	15,30	0,0496	43,0	6,08	4,01	2,21	2,03	2,92	P
OF 60.2.5	60	40	20	2,5	2,5	367	3,00	5,15	4,59	22,00	18,30	0,0956	50,6	7,34	4,89	2,19	2,00	3,60	C
OF 60.3.0	60	40	20	3,0	3,0	361	3,00	5,12	5,41	25,30	21,00	0,1620	56,1	8,44	5,68	2,16	1,97	4,25	C
OF 80.2.5	80	50	25	2,5	2,5	487	4,00	6,95	6,09	52,60	38,80	0,1268	198,0	13,10	8,17	2,94	2,52	4,78	P
OF 80.3.0	80	50	25	3,0	3,0	481	4,00	6,92	7,21	61,00	45,00	0,2160	225,0	15,30	9,57	2,91	2,50	5,66	C
OF 100.2.5	100	50	30	2,5	2,5	587	4,83	8,48	7,34	96,90	50,70	0,1529	471,0	18,80	9,66	3,63	2,63	5,76	P
OF 100.3.0	100	50	30	3,0	3,0	581	4,83	8,45	8,71	113,00	59,00	0,2610	539,0	21,90	11,30	3,61	2,60	6,94	C

Tabla 2.A3.7. Placa ondulada

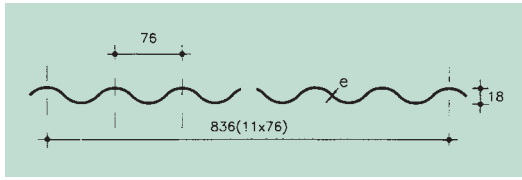

u = Perímetro de la sección
 A = Área de la sección
 I = Momento de inercia
 W = Módulo resistente de la sección
 $i = 1 : A$. Radio de giro

Placa	Dimensiones		Términos de sección				Peso	
	e mm	u mm	A cm ²	I cm ⁴	W cm ³	i cm	p kp/m ²	
O.0.5	0,5	2.000	5,00	2,00	2,22	0,63	4,38	C
O.0.6	0,6	2.000	6,00	2,38	2,64	0,63	5,20	C
O.0.8	0,8	2.000	8,00	3,70	4,11	0,68	7,00	C
O.1.0	1,0	2.000	10,00	4,65	5,16	0,68	8,77	C
O.1.2	1,2	2.000	12,00	5,60	6,22	0,68	10,50	C

Tabla 2.A3.8. Placa gredada

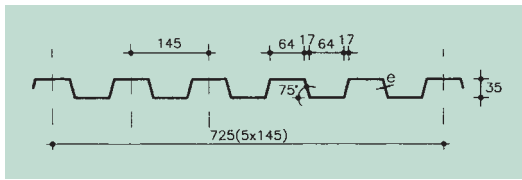

u = Perímetro de la sección
 A = Área de la sección
 I = Momento de inercia
 W = Módulo resistente de la sección
 $i = 1 : A$. Radio de giro

Placa	Dimensiones		Términos de sección				Peso	
	e mm	u mm	A cm ²	I cm ⁴	W cm ³	i cm	p kp/m ²	
G.0.5	0,5	2.300	5,25	11,9	6,28	1,51	5,89	C
G.0.6	0,6	2.300	6,30	14,3	7,53	1,51	7,07	C
G.0.8	0,8	2.300	8,40	19,0	9,94	1,51	9,42	C
G.1.0	1,0	2.300	10,50	23,7	12,30	1,50	11,80	C
G.1.2	1,2	2.300	12,60	28,4	14,70	1,50	14,10	C